

INSTALLATION INSTRUCTIONS FOR KITS #1-206, #1-207 & #1-208 AMC FRONT CONTROL ARM BUSHINGS

- 1) CONTROL ARM BUSHINGS ARE DESIGNED TO REPLACE THE RUBBER PORTION OF THE ORIGINAL BUSHING AND INNER SLEEVE. THEREFORE THE ORIGINAL OUTER METAL SHELLS MUST BE REUSED.
- 2) REMOVE CONTROL ARM BEING CAREFUL NOT TO DAMAGE ANY PARTS THAT ARE TO BE REUSED. REMOVAL OF THE ORIGINAL RUBBER BUSHING IS BEST ACCOMPLISHED BY PRESSING OUT THE BUSHING AND SLEEVE FROM THE SHELL OR BY BURNING AWAY THE ORIGINAL RUBBER MATERIAL. PAY CAREFUL ATTENTION TO OTHER ADJOINING PARTS THAT COULD BE DAMAGED BY HEAT. **CAUTION-THIS SHOULD BE DONE BY A QUALIFIED SPECIALIST AS IT IS EXTREMELY DANGEROUS.**
- 3) REMOVE ALL OF THE ORIGINAL RUBBER BUSHING MATERIAL AND CLEAN CONTACT SURFACES. THIS CAN BE DONE BY WIRE BRUSHING, SANDBLASTING OR SIMILAR PROCESS.
- 4) LIGHTLY GREASE I.D., O.D. AND FLANGE OF BUSHINGS AND O.D. OF SLEEVES. ALSO I.D. OF CONTROL ARM AND ALL SURFACES THAT BUSHING CONTACTS. USE SPECIAL SUPER GREASE™ INCLUDED IN KIT. IF MORE GREASE IS NEEDED, OBTAIN SUPER GREASE™ FROM YOUR DEALER (PART #19-1750). IT IS RECOMMENDED THAT YOU USE ONLY OUR SPECIAL SUPER GREASE™.
- 5) INSTALL NEW PROTHANE™ BUSHINGS AS DIAGRAM SHOWS.
- 6) REINSTALL THE CONTROL ARMS ONTO THE VEHICLE AS PER THE MANUFACTURER'S SHOP MANUAL.
- 7) ALIGN FRONT OF VEHICLE.
- 8) AFTER DRIVING VEHICLE FOR APPROXIMATELY 50 MILES, RE-TORQUE BUSHING RETAINING NUTS AND OR BOLTS TO BE SURE THEY HAVE NOT LOOSENED DUE TO THE BUSHING SETTLING IN. REPEAT THIS PROCEDURE AFTER VEHICLE IS RACED, DRIVEN OFFROAD OR DRIVEN IN ABUSIVE CONDITIONS.

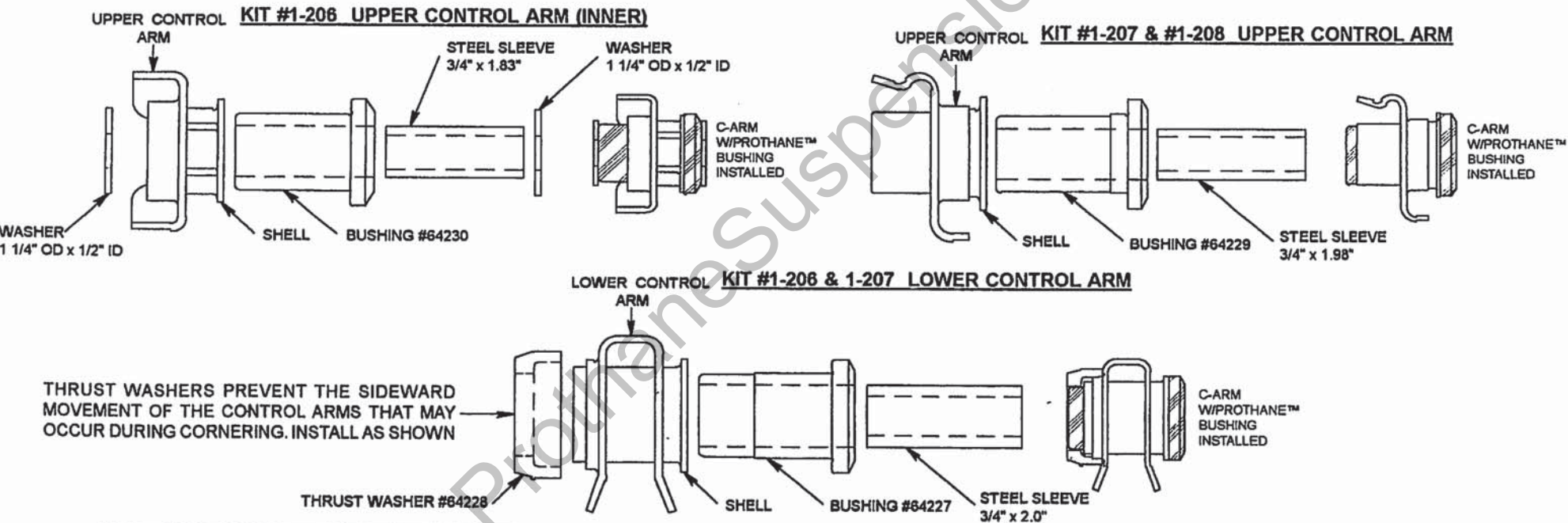

PARTS LIST FOR KIT #1-206		
PART#	DESCRIPTION	QTY
U-64230	UPPER C-ARM BUSHING (INNER)	4
U-64234	UPPER C-ARM BUSHING (OUTER)	4
U-64227	LOWER C-ARM BUSHING	2
U-64228	LOWER C-ARM THRUST WASHER	2
SLV-60817	3/4"OD x 1.830" STEEL SLEEVE	4
SLV-60818	7/8"OD x 2.050" STEEL SLEEVE	2
SLV-60820	3/4"OD x 2.020" STEEL SLEEVE	2
WASH-1187	1 1/4"OD x 1/2"ID WASHER	8
19-1750-001	SUPER GREASE™	3

PARTS LIST FOR KIT #1-207		
PART#	DESCRIPTION	QTY
U-64229	UPPER C-ARM BUSHING	4
U-64227	LOWER C-ARM BUSHING	2
U-64228	LOWER C-ARM THRUST WASHER	2
SLV-60818	7/8"OD x 2.050" STEEL SLEEVE	2
SLV-60819	3/4"OD x 1.980" STEEL SLEEVE	4
19-1750-001	SUPER GREASE™	3

PARTS LIST FOR KIT #1-208		
PART#	DESCRIPTION	QTY
U-64229	UPPER C-ARM BUSHING	4
SLV-60819	3/4"OD x 1.980" STEEL SLEEVE	4
19-1750-001	SUPER GREASE™	2