

## INSTRUCTIONS FOR MITSUBISHI MOTOR MOUNT INSERT KITS

- 1) Securely support the weight of the engine and transmission. Remove original motor mount.
- 2) The complete rubber portion of the mount must be removed from the bracket including the pressed-in steel outer shell. The original mount/bracket will be reused. Note: original mounts may be aluminum or steel(see diagram). Remove the rubber mount bushing by pressing out with an arbor press. Do not damage mount/bracket.
- 3) Clean the inside of the mount/bracket in preparation for the new bushings. De-burr if necessary.
- 4) Install the new bushing by lightly greasing the leading edge of one side of the bushing and pressing it into the mount/bracket. Press bushing thru until the lip is completely exposed on the opposite side of the mount.
- 5) Install new gold zinc plated steel center sleeve by hand. No grease is required.
- 6) Bolt new mount back onto engine/transmission/chassis first, and then maneuver the engine/transmission back into position. Install thru-bolt and tighten to factory specifications. Repeat steps 1 thru 6 for each mount.

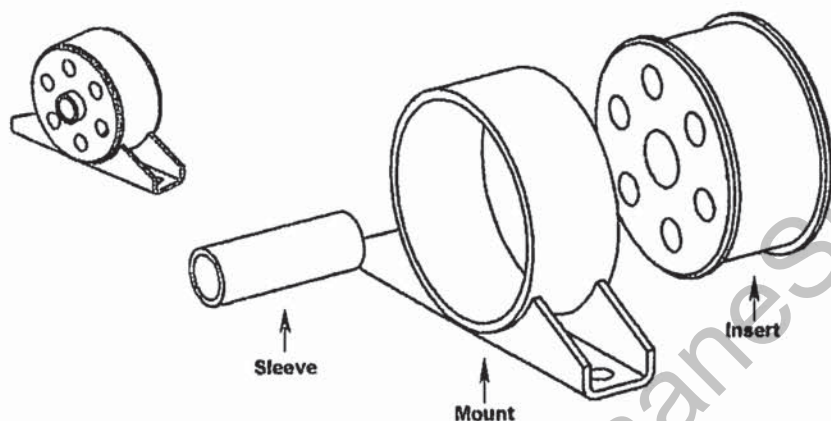

### PARTS LIST FOR 13-507

PART #	DESC.	QTY
U-69151	INSERT BUSHING	1
SLV-60917	7/8x11/16IDx2.45L SLEEVE	1

### PARTS LIST FOR 13-508

PART #	DESC.	QTY
U-69152	INSERT BUSHING	1
SLV-60918	7/8x1/2IDx2.60L SLEEVE	1

## INSTRUCTIONS FOR MITSUBISHI MOTOR MOUNT INSERT KITS

- 1) Securely support the weight of the engine and transmission. Remove original motor mount.
- 2) The complete rubber portion of the mount must be removed from the bracket including the pressed-in steel outer shell. The original mount/bracket will be reused. Note: original mounts may be aluminum or steel(see diagram). Remove the rubber mount bushing by pressing out with an arbor press. Do not damage mount/bracket.
- 3) Clean the inside of the mount/bracket in preparation for the new bushings. De-burr if necessary.
- 4) Install the new bushing by lightly greasing the leading edge of one side of the bushing and pressing it into the mount/bracket. Press bushing thru until the lip is completely exposed on the opposite side of the mount.
- 5) Install new gold zinc plated steel center sleeve by hand. No grease is required.
- 6) Bolt new mount back onto engine/transmission/chassis first, and then maneuver the engine/transmission back into position. Install thru-bolt and tighten to factory specifications. Repeat steps 1 thru 6 for each mount.

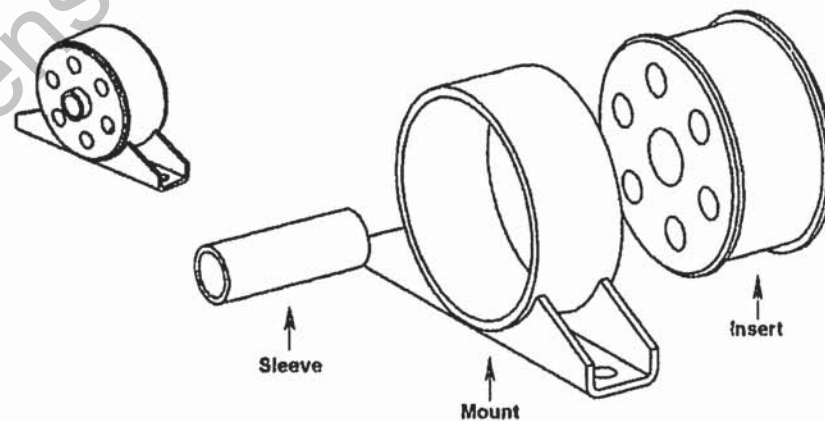

### PARTS LIST FOR 13-507

PART #	DESC.	QTY
U-69151	INSERT BUSHING	1
SLV-60917	7/8x11/16IDx2.45L SLEEVE	1

### PARTS LIST FOR 13-508

PART #	DESC.	QTY
U-69152	INSERT BUSHING	1
SLV-60918	7/8x1/2IDx2.60L SLEEVE	1