

## BODY MOUNT ASSEMBLY INSTRUCTIONS FOR KIT #18-103

- 1) NOTE ALL BODY MOUNT POSITIONS AND RESPECTIVE PARTS (MOUNT SIZE/TYPE, WASHERS, SPACERS, BOLTS, SHIMS, ETC.) BEFORE AND DURING DISASSEMBLY. YOU WILL HAVE TO REUSE CERTAIN FACTORY HARDWARE PIECES THAT ARE NOT INCLUDED IN KIT.
- 2) THE FRONT BUMPER MUST BE REMOVED BEFORE RAISING THE BODY.
- 3) IF MOUNTING BOLTS AND NUTS ARE RUSTED, LIBERALLY SPRAY WITH PENETRATING OIL I.E. WD-40.
- 4) SUPPORT VEHICLE BODY PROPERLY BEFORE REMOVING MOUNTS. USE A 2"X4" PIECE OF WOOD 24" LONG (OR ANY OTHER SUITABLE SIZE) BETWEEN JACK AND BODY PANEL TO SPREAD THE WEIGHT LOAD OUT SO AS NOT TO DAMAGE THE BODY PANELS. IF NECESSARY, SUPPORT BODY IN SEVERAL AREAS.
- 5) LOOSEN ALL BOLTS AND NUTS BUT DO NOT REMOVE.
- 6) WORKING FROM ONLY ONE SIDE OF VEHICLE AT A TIME REMOVE MOUNTING BOLT AND NUT AND RAISE BODY ONLY HIGH ENOUGH TO REPLACE MOUNT, NEVER HIGHER. ALSO CHECK OTHER AREAS ON BODY AND FRAME TO AVOID ANY INTERFERENCE PROBLEMS WHEN RAISING BODY.
- 7) REPLACE MOUNTS ONE AT A TIME. A DIAGRAM HAS BEEN PROVIDED FOR INFORMATION AS TO WHICH MOUNTS, WASHERS, SLEEVES AND BOLTS TO USE FOR EACH POSITION. INSTALL BOLTS BUT DO NOT TIGHTEN UNTIL ALL MOUNTS HAVE BEEN REPLACED.
- 8) AFTER ALL MOUNTS HAVE BEEN REPLACED, ALIGN SUBFRAME TO BODY AND TORQUE BOLTS TO FACTORY SPECIFICATIONS.
- 9) AFTER DRIVING VEHICLE FOR ABOUT 1000 MILES OR OFF ROADING, RE-TORQUE BOLTS AGAIN. THIS IS TO INSURE THAT THE BOLTS HAVE NOT LOOSEENED DUE TO INITIAL SETTLING THAT MAY TAKE PLACE.

### MOUNTING POSITIONS

MOUNTING POSITIONS ARE NUMBERED STARTING WITH #1 FOR THE MOST FORWARD POSITION TOWARD THE FRONT OF THE VEHICLE AND RESPECTIVELY HIGHER NUMBERS TOWARD THE REAR OF THE VEHICLE.

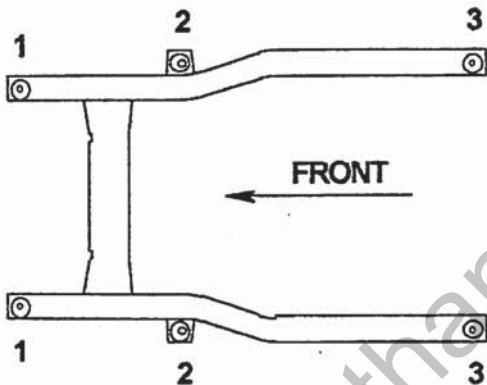

### #1 POSITION BODY MOUNT

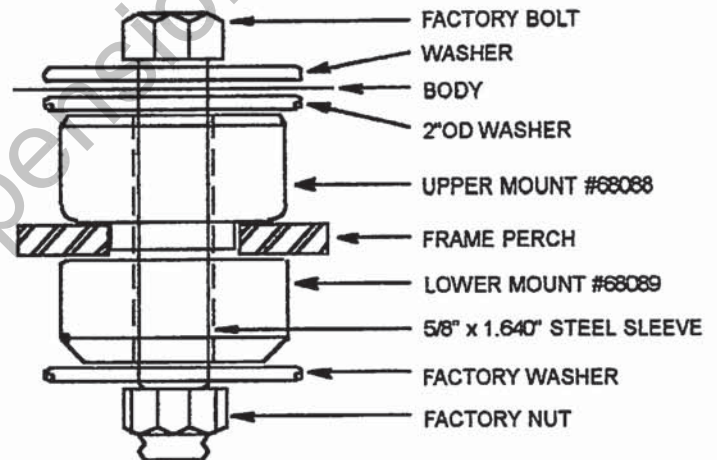

### #2 & #3 POSITIONS BODY MOUNT

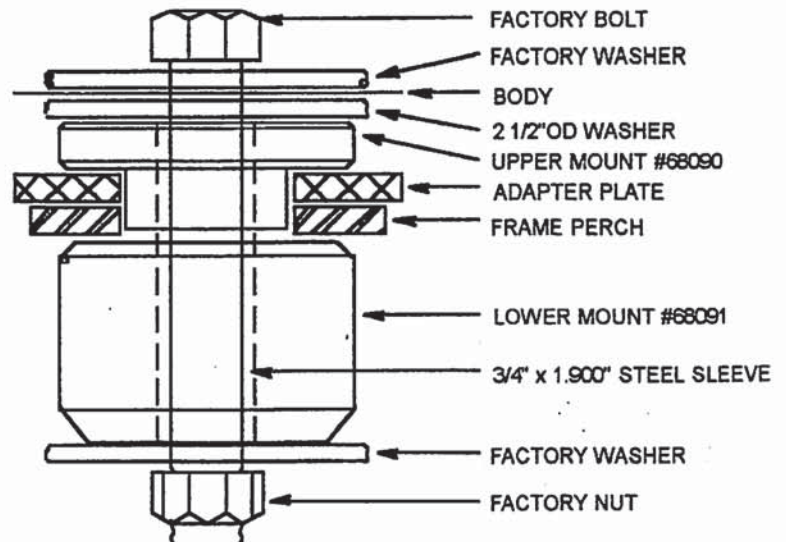

### PARTS LIST FOR KIT #18-103

PART#	DESCRIPTION	QTY	POS.#
U-68088	UPPER BODY MOUNT (SMALL)	2	1
U-68089	LOWER BODY MOUNT (SMALL)	2	1
U-68090	UPPER BODY MOUNT (LARGE)	4	2,3
U-68091	LOWER BODY MOUNT (LARGE)	4	2,3
SLV-60828	5/8" x 1.640" STEEL SLEEVE	2	1
SLV-60829	3/4" x 1.900" STEEL SLEEVE	4	2,3
WASH-1157	2"OD x 3/8"ID WASHER	2	1
WASH-64	2 1/2"OD x 7/16"ID WASHER	4	2,3
PLT-1270	ADAPTER PLATE	4	2,3