

GENERAL BODY MOUNT ASSEMBLY INSTRUCTIONS

NOTE ALL BODY MOUNT POSITIONS AND RESPECTIVE PARTS (MOUNT SIZE/TYPE, WASHERS, SPACERS, BOLTS, SHIMS, ETC.) BEFORE AND DURING DISASSEMBLY. YOU MAY HAVE TO REUSE CERTAIN FACTORY HARDWARE PIECES THAT ARE NOT INCLUDED IN KIT.

1) MOUNTING BOLTS AND NUTS ARE RUSTED, LIBERALLY SPRAY WITH PENETRATING OIL (I.E., WD-40).

2) SUPPORT VEHICLE BODY PROPERLY BEFORE REMOVING MOUNTS. USE A 2"X4" PIECE OF WOOD 24" LONG (OR ANY OTHER SUITABLE SIZE) BETWEEN JACK AND BODY PANEL TO SPREAD THE WEIGHT LOAD OUT SO AS NOT TO DAMAGE THE BODY PANELS. IF NECESSARY, SUPPORT BODY IN SEVERAL AREAS.

3) LOOSEN ALL BOLTS AND NUTS BUT DO NOT REMOVE.

4) WORKING FROM ONLY ONE SIDE OF VEHICLE AT A TIME REMOVE MOUNTING BOLT AND NUT AND RAISE BODY ONLY HIGH ENOUGH TO REPLACE MOUNT, NEVER HIGHER. ALSO CHECK OTHER AREAS ON BODY AND FRAME TO AVOID ANY INTERFERENCE PROBLEMS WHEN RAISING BODY.

5) REPLACE MOUNTS ONE AT A TIME. IF NECESSARY, A DIAGRAM HAS BEEN PROVIDED FOR INFORMATION AS TO WHICH MOUNTS, WASHERS, SLEEVES AND BOLTS TO USE FOR EACH POSITION. INSTALL BOLTS BUT DO NOT TIGHTEN UNTIL ALL MOUNTS HAVE BEEN REPLACED.

6) AFTER ALL MOUNTS HAVE BEEN REPLACED, TORQUE BOLTS TO FACTORY SPECIFICATIONS.

7) AFTER DRIVING VEHICLE FOR ABOUT 1000 MILES OR OFF ROADING RE-TORQUE BOLTS AGAIN. THIS IS TO INSURE THAT THE BOLTS HAVE NOT LOOSENED DUE TO INITIAL SETTLING THAT MAY TAKE PLACE.

PARTS ASSEMBLY LIST FOR KIT # 7-135

MOUNTING POSITIONS ARE NUMBERED STARTING WITH #1 FOR THE MOST FORWARD POSITION TOWARD THE FRONT OF THE VEHICLE AND RESPECTIVELY HIGHER NUMBERS TOWARD THE REAR OF THE VEHICLE.

PARTS ARE LISTED FROM TOP (#1) TO BOTTOM.

1 MOUNT

- 1) FACTORY WASHER
- 2) UPPER MOUNT #68069
- 3) LOWER MOUNT #68068
- 4) FACTORY SLEEVE
- 5) 2" OD X 1/2" ID FLAT WASHER
- 6) REUSE FACTORY BOLT & NUT

2 MOUNT

- 1) FACTORY WASHER
- 2) UPPER MOUNT #60332
- 3) LOWER MOUNT #68068
- 4) FACTORY SLEEVE
- 5) 2" OD X 1/2" ID FLAT WASHER
- 6) REUSE FACTORY BOLT & NUT

3 MOUNT

- 1) FACTORY WASHER
- 2) UPPER MOUNT #60346
- 3) LOWER MOUNT #60357
- 4) FACTORY SLEEVE
- 5) 2" OD X 1/2" ID FLAT WASHER
- 6) REUSE FACTORY BOLT & NUT

4 MOUNT

- 1) FACTORY WASHER
- 2) UPPER MOUNT #60347
- 3) LOWER MOUNT #60334
- 4) FACTORY SLEEVE *(SEE NOTE BELOW)
- 5) 2" OD X 1/2" ID FLAT WASHER
- 6) 1/2" X 5" BOLT SUPPLIED IN KIT

TYPICAL BODY MOUNT

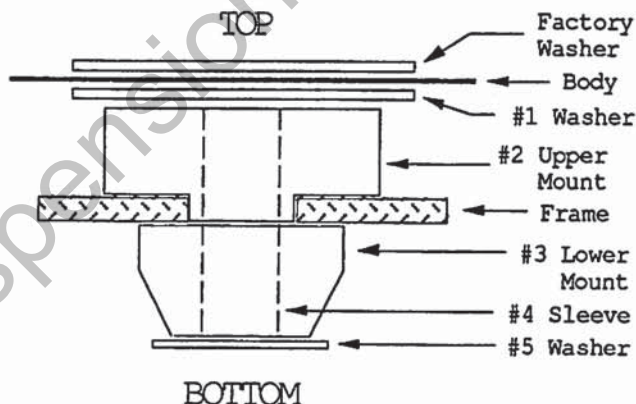

PARTS LIST FOR KIT #7-135

PART #	DESCRIPTION	QTY
U-60332	BODY MOUNT	2
U-60334	BODY MOUNT	2
U-60346	BODY MOUNT	2
U-60347	BODY MOUNT	2
U-60357	BODY MOUNT	2
U-68068	BODY MOUNT	4
U-68069	BODY MOUNT	2
BOLT-1165	1/2"-13 X 5" BOLT	2
WASH-1159	2"OD X 1/2"ID WASHER	8

* NOTE: IT WILL BE NECESSARY TO SHORTEN THE STOCK SLEEVES ON THIS MOUNT TO 3 3/4". MOST OF THE SLEEVES ARE HEAT TREATED AND MAY BE DIFFICULT TO CUT. BE SURE THE SHORTENED END OF SLEEVES ARE SQUARE WHEN FINISHED.

