

INSTALLATION INSTRUCTIONS FOR TRANSMISSION INSERT KIT #7-514 & 7-515

Prothane Motion Control highly recommends this and all our polyurethane suspension kits be installed by a qualified automotive technician.

- 1) Support the weight of the transmission with a floor jack or similar device.
- 2) Remove the transmission mount from the vehicle per repair manual procedure.
- 3) Remove the original rubber bushing from the mount bracket. To do this bend the four metal tabs away from the bracket (see diagram). Then lightly tap the bushing out using a rubber mallet.

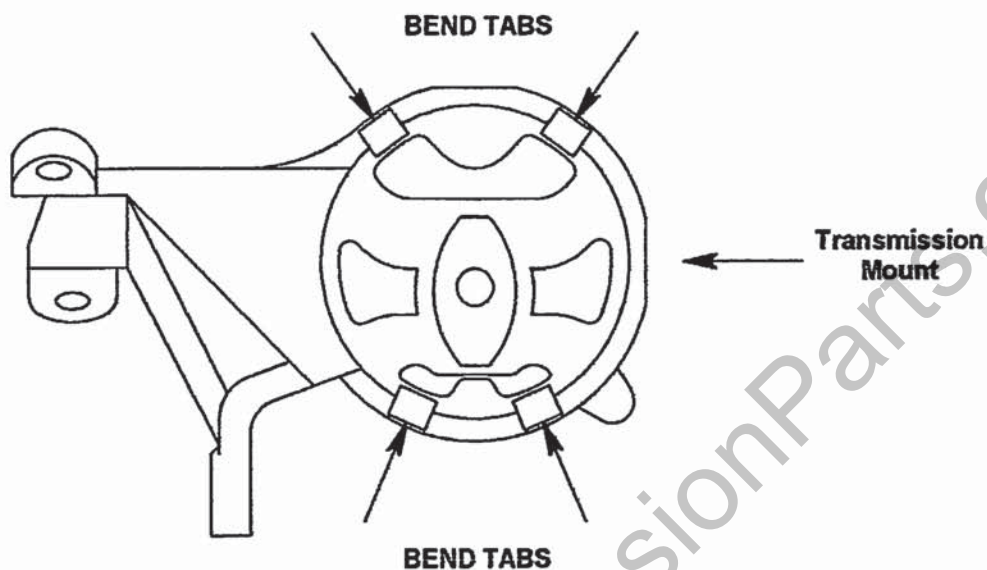

- 4) Install the new bushing in the bracket by placing the bevelled edge of the bushing onto the bevelled edge of the bracket. See diagram below. Press the bushing all the way into the bracket using an arbor press or bench vice.
- 5) Install the steel sleeve into the new bushing.
- 6) Reinstall the mount, attaching it to the transmission first and then to the chassis. Tighten all bolts to original manufacturer's specifications.

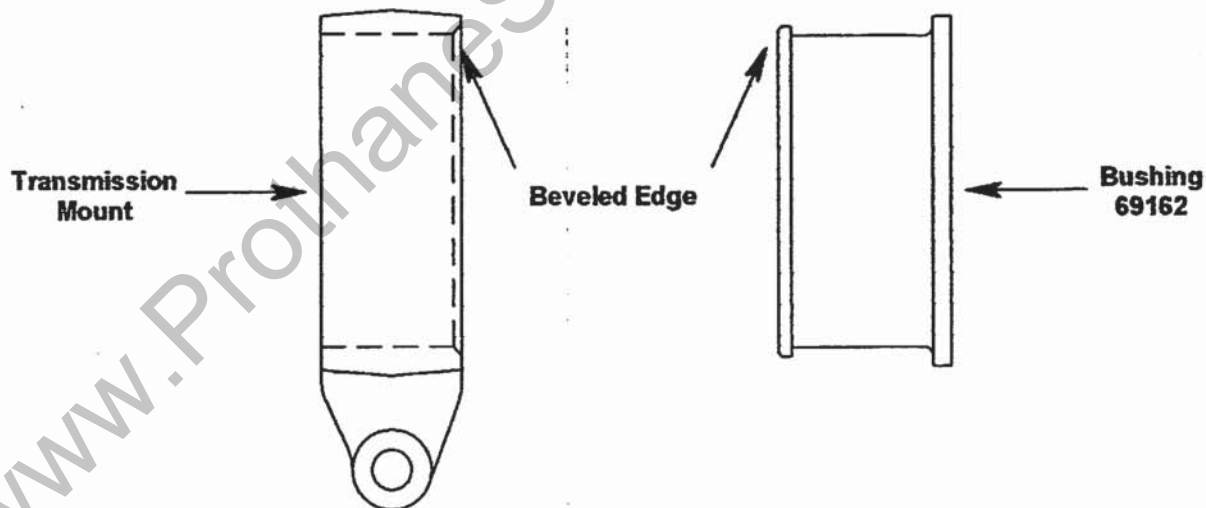

PARTS LIST FOR KIT #7-514

| Part # | Description | Qty |
|-----------|-------------|-----|
| U-69162 | Bushing | 1 |
| SLV-60924 | 3/4"x2.870 | 1 |



PARTS LIST FOR KIT #7-515

| Part # | Description | Qty |
|-----------|-------------|-----|
| U-69162 | Bushing | 1 |
| SLV-60923 | 3/4"x2.600 | 1 |